

EXPECTED GAPS BETWEEN PRIME NUMBERS

FRED B. HOLT

ABSTRACT. We study the gaps between consecutive prime numbers directly through Eratosthenes sieve. Using elementary methods, we identify a recursive relation for these gaps and for specific sequences of consecutive gaps, known as constellations. Using this recursion we can estimate the numbers of a gap or of a constellation that occur between a prime and its square. This recursion also has explicit implications for open questions about gaps between prime numbers, including three questions posed by Erdős and Turán.

KEYWORDS: primes, twin primes, gaps, distribution of primes, Eratosthenes sieve.

1. INTRODUCTION

We work with the prime numbers in ascending order, denoting the k^{th} prime by p_k . Accompanying the sequence of primes is the sequence of gaps between consecutive primes. We denote the gap between p_k and p_{k+1} by $g_k = p_{k+1} - p_k$. These sequences begin

$$\begin{array}{cccccccc} p_1 = 2, & p_2 = 3, & p_3 = 5, & p_4 = 7, & p_5 = 11, & p_6 = 13, & \dots \\ g_1 = 1, & g_2 = 2, & g_3 = 2, & g_4 = 4, & g_5 = 2, & g_6 = 4, & \dots \end{array}$$

A number d is the *difference* between prime numbers if there are two prime numbers, p and q , such that $q - p = d$. There are already many interesting results and open questions about differences between prime numbers; a seminal and inspirational work about differences between primes is Hardy and Littlewood's 1923 paper [10].

A number g is a *gap* between prime numbers if it is the difference between consecutive primes; that is, $p = p_i$ and $q = p_{i+1}$ and $q - p = g$. Differences of length 2 or 4 are also gaps; so open questions like the Twin Prime Conjecture, that there are an infinite number of gaps $g_k = 2$, can be formulated as questions about differences as well.

Date: 2 Feb 06.

1991 Mathematics Subject Classification. 11N05, 11A41, 11A07.

Key words and phrases. primes, twin primes, gaps, prime constellations, Eratosthenes sieve.

A *constellation among primes* [22] is a sequence of consecutive gaps between prime numbers. Let $s = a_1 a_2 \cdots a_k$ be a sequence of k numbers. Then s is a constellation among primes if there exists a sequence of $k + 1$ consecutive prime numbers $p_i p_{i+1} \cdots p_{i+k}$ such that for each $j = 1, \dots, k$, we have the gap $p_{i+j} - p_{i+j-1} = a_j$. Equivalently, s is a constellation if for some i and all $j = 1, \dots, k$, $a_j = g_{i+j}$.

We will write the constellations without marking a separation between single-digit gaps. For example, a constellation of 24 denotes a gap of $g_k = 2$ followed immediately by a gap $g_{k+1} = 4$. The number of gaps after k iterations of the sieve is $\Phi_k = \prod_{i=1}^k (p_i - 1)$. For the small primes we will consider explicitly, most of these gaps are single digits, and the separators introduce a lot of visual clutter. We use commas only to separate double-digit gaps in the cycle. For example, a constellation of 2, 10, 2 denotes a gap of 2 followed by a gap of 10, followed by another gap of 2.

We use elementary methods to study the gaps generated by Eratosthenes sieve directly. By studying this sieve, we can estimate the occurrence of certain gaps and constellations between p_k and p_k^2 .

From the methods developed below, we can calculate exactly how many times a sequence s of gaps occurs after k stages of Eratosthenes' sieve. We don't know how many of these occurrences will survive subsequent stages of the sieve to become constellations among prime numbers. However, for a prime p we can make estimates for the number that occur before p^2 , all of which will survive as constellations among primes. Thus our estimates and counts are only coincidentally commensurate with tabulations against powers of ten.

The product of the first k primes will be denoted by $\Pi_k = \prod_{i=1}^k p_i$.

By the p_k -sieve, we mean those positive integers remaining after removing all the multiples of the first k prime numbers. The p_k -sieve has a fundamental cycle of Φ_k elements modulo Π_k . Most often we picture this fundamental cycle as the generators for $\mathbb{Z} \bmod \Pi_k$, although it is also attractive to visualize these as the primitive Π_k^{th} roots of unity in \mathbb{C} .

1.1. Organization of the material. We proceed as follows. We identify a recursive algorithm for producing each cycle of gaps $\mathcal{G}(p_{k+1})$ from the preceding cycle $\mathcal{G}(p_k)$. This recursion enables us to enumerate various gaps and constellations in the p_k -sieve. In the cycle of gaps $\mathcal{G}(p_k)$ of course, all the gaps from p_{k+1} and p_{k+1}^2 are actually gaps between prime numbers.

We make a conjecture about the uniformity of the distribution of these gaps and constellations. From this conjecture we can make statistical estimates about the expected number of occurrences of these gaps and constellations below p_{k+1}^2 , and we compare these estimates with actual counts.

We make a weaker conjecture that every constellation in $\mathcal{G}(p_k)$ occurs infinitely often as a constellation among primes, provided the sum of the gaps in the constellation is less than $2p_{k+1}$. From this weaker conjecture we address several questions about gaps and differences between prime numbers. We show that Hardy and Littlewood's k -tuple conjecture on the differences between prime numbers [10] is equivalent to a conjecture on gaps. We are also able to give exact answers to three questions posed by Erdős and Turán [6].

1.2. New results. This paper applies elementary methods to Eratosthenes sieve. In a general sense, this is well-trodden ground. However, the specific insight of identifying the recursion on gaps appears to be new. We cast Eratosthenes sieve as a recursive operation directly on the cycle of gaps. By studying this recursion we can enumerate particular gaps at every stage. Moreover we observe how much structure of the cycle of gaps at one stage of the sieve is preserved in subsequent stages. We can thereby easily enumerate the occurrences of specific constellations of primes that have not previously been approachable (e.g. 2, 10, 2).

The conclusions on the recursion of gaps are precise. To go further, we need to supplement our rigorous work with an appropriate conjecture. We first make a strong conjecture, that under the recursion the copies of a specific constellation eventually approach a uniform distribution in the cycle. This conjecture on a uniform distribution allows us to make estimates of the occurrences of constellations in the sieve as constellations among prime numbers. These new estimates compare favorably with existing estimates, and they allow us to estimate the occurrences of other interesting constellations that have lain beyond the reach of existing techniques.

Backing off from the strong conjecture on uniformity, we make a weaker conjecture, that sufficiently small constellations in the sieve occur infinitely often as constellations among prime numbers. This conjecture implies that the Twin Prime Conjecture is true. However, it goes further. By identifying specific constellations and using the action of the recursion, we answer three questions posed Erdős and Turán [6]:

- i) *Spikes.* $\limsup g_n/g_{n+1} = \infty$ and $\liminf g_n/g_{n+1} = 0$
- ii) *Oscillation.* There is no n_0 such that for all $k \geq 1$, $g_{n_0+2k-1} < g_{n_0+2k}$ and $g_{n_0+2k} > g_{n_0+2k+1}$.
- iii) *Superlinearity.* $g_j < g_{j+1} < \dots < g_{j+k}$ does have infinitely many solutions for every k .

The progress exhibited in this paper is the result of new elementary insights into Eratosthenes sieve. Specifically, we can track the cycle of gaps explicitly through stages of the sieve. While previous methods have jumped immediately to probabilistic estimates, we examine the deterministic effect

that the recursion has on subsequences in the cycle of gaps. Only after we have exhausted the exact results on these constellations, do we turn to simpler probabilistic estimates.

2. RELATED RESULTS

There are of course several avenues of research into the distribution of primes. Research into constellations has been motivated primarily by two conjectures: the twin primes conjecture, and Hardy and Littlewood's broader k -tuple conjecture [10, 20].

The twin primes conjecture asserts that the gap $g = 2$ occurs infinitely often. Work on this conjecture has included computer-based enumerations [12, 15, 18] and investigations of Brun's constant [8, 22, 10, 20]. Brun's constant is the sum of the reciprocals of twin primes. This series is known to converge, and the sharpest current estimate [20] is 1.902160577783278. One generalization of the twin primes conjecture is a conjecture by Polignac from 1849 [20] that for every even positive integer N there are an infinite number of gaps $g_k = N$.

Hardy and Littlewood [10, 21] formulated their prime k -tuples conjecture in this form: if b_1, \dots, b_k is an admissible k -tuple, then there are infinitely many x such that $x + b_1, \dots, x + b_k$ are all prime. Admissibility in this context is a condition on residue classes modulo smaller primes.

The work in [10] supports related conjectures estimating the numbers of specific differences that should occur in the interval $[2, N]$ for any N . For a difference d , their Conjecture B asserts that the number $C_d(N)$ of prime pairs $(p, p + d)$ with $p \leq N$ is asymptotically

$$(1) \quad C_d(N) \sim 2c_2 \prod_{q|d} \frac{q-1}{q-2} \int_2^N \frac{dx}{\ln^2 x}$$

$$(2) \quad \sim 2c_2 \frac{N}{\ln^2 N} \prod_{q|d} \frac{q-1}{q-2}$$

in which q runs over the odd primes. The constant c_2 , known as the *twin prime constant* [10, 22] is given by the infinite product

$$c_2 = \prod \frac{p(p-2)}{(p-1)^2} = 0.6601618\dots$$

For an admissible k -tuple b_1, \dots, b_k , Hardy and Littlewood [10] conjectured the general estimate

$$(3) \quad C_b(N) \sim 2^k \prod_q \left(\frac{q}{q-1} \right)^{k+1} (1 - \phi_q(b)/q) \cdot \int_2^N \frac{dx}{\ln^{k+1} x}$$

in which q runs over the odd primes and $\phi_q(b)$ is the number of distinct residue classes of $0, b_1, \dots, b_k$ modulo q .

Hardy and Littlewood's prime k -tuple conjecture addresses differences among primes, but the primes in question need not be consecutive. However the k -tuple conjecture has an equivalent formulation as a conjecture on constellations, which we will see in Lemma 6.1 below. For the differences $d = 2, 4$ the estimates (1) are also estimates for the corresponding gaps $g = 2, 4$.

Most estimates for sequences of differences, e.g. [10, 14], are derived by treating probabilities on residues as independent probabilities. In contrast, the recursion identified below in Lemma 3.1 preserves the structure in the cycles of gaps at each stage of Eratosthenes sieve. The occurrence of constellations in stages of the sieve is entirely deterministic.

Computational confirmation of these estimates has been carried out by several researchers, notably in [3, 15]. The results in this paper and the tables and examples previously published are not quite commensurate. The tables and examples of [2, 12, 16, 15] provide estimates and counts of gaps with respect to large powers of ten. Since we work directly with Eratosthenes sieve, our estimates are given with respect to intervals $[p, p^2]$ for primes p .

Some researchers have applied their investigations of differences among primes to study gaps and constellations. The general surveys [20, 22] provide overviews of some of this work, and the estimate (3) from the seminal paper [10] can be used for constellations consisting of 2's and 4's, e.g. 24, 42, 242, 424, etc. Brent [2] applied the principle of inclusion and exclusion to the estimates (3) to obtain strong estimates for the gaps 2, 4, 6, \dots , 80. Richards [21] conjectured that the constellation 24 occurs infinitely often. Clement [4] and Nicely [17] have addressed the constellation 242, corresponding to *prime quadruplets*, pairs of twin primes separated by a gap of 4.

There are other lines of investigation [20, 7] into the gaps between prime numbers. One line [23, 16, 13, 1] has looked for the first occurrence of a gap. Cramer [5] introduced probabilistic arguments to derive asymptotic estimates for the sequence of gaps $g_k = \mathcal{O}(\ln^2 p_k)$. Quite recently, Green and Tao [9] have offered a proof that there exist arbitrarily long sequences of primes in arithmetic progression. By working with the convex hulls of the graphs of primes (k, p_k) and of the log-primes $(k, \ln p_k)$, Pomerance [19] established a handful of nice results about inequalities involving the arithmetic and geometric means of prime numbers.

3. RECURSION FOR THE CYCLE OF GAPS

The possible primes for the 3-sieve are

$$(1), 5, 7, 11, 13, 17, 19, 23, 25, 29, 31, 35, 37, 41, 43, \dots$$

We investigate the structure of these sequences of possible primes by studying the cycle of gaps in the fundamental cycle. For example, 42 is the cycle of gaps for the 3-sieve. We have

$$\mathcal{G}(3) = 42, \text{ with } g_{3,1} = 4 \text{ and } g_{3,2} = 2.$$

The lowest entry in the cycle of gaps is one less than the next prime: $g_{k,1} = p_{k+1} - 1$. Denote the sum of the first j gaps in $\mathcal{G}(p_k)$ by $\Gamma_{k,j} = \sum_{i=1}^j g_{k,i}$. For the p_k -sieve, the j^{th} possible prime is given by $1 + \Gamma_{k,j}$. Since we are studying the cycle of gaps in the p_k -sieve, we know that there are Φ_k elements in one cycle, and the sum of the gaps in one cycle must be Π_k :

$$\Gamma_{k,\Phi_k} = \Pi_k.$$

There is a nice recursion which produces $\mathcal{G}(p_{k+1})$ from $\mathcal{G}(p_k)$. We concatenate p_{k+1} copies of $\mathcal{G}(p_k)$, and add together certain gaps as indicated by the entry-wise product $p_{k+1} * \mathcal{G}(p_k)$. So the recursion consists of three steps.

Lemma 3.1. *The cycle of gaps $\mathcal{G}(p_{k+1})$ is derived recursively from $\mathcal{G}(p_k)$. Each stage in the recursion consists of the following three steps:*

- R1. Determine the next prime, $p_{k+1} = g_{k,1} + 1$.
- R2. Concatenate p_{k+1} copies of $\mathcal{G}(p_k)$.
- R3. Add together $g_{k,1} + g_{k,2}$, and record the index for the location of this addition as $\tilde{i}_1 = 1$; for $n = 1, \dots, \Phi_k - 1$, add $g_{k,j} + g_{k,j+1}$ and let $\tilde{i}_{n+1} = j$ if

$$\Gamma_{k,j} - \Gamma_{k,\tilde{i}_n} = p_{k+1} * g_{k,n}.$$

Proof. We consider the cycle of gaps in relation to the generators of $\mathbb{Z} \bmod \Pi_k$. Suppose the differences between consecutive generators in $\mathbb{Z} \bmod \Pi_k$ is the cycle of gaps $\mathcal{G}(p_k)$. By induction, we will show this relation holds for $\mathcal{G}(p_{k+1})$ and $\mathbb{Z} \bmod \Pi_{k+1}$.

The next prime p_{k+1} will be $1 + g_{k,1}$, since this will be the smallest integer both greater than 1 and coprime to Π_k .

The second step of the recursion extends our list of possible primes up to $\Pi_{k+1} + 1$, the reach of the fundamental cycle for p_{k+1} . For the gaps $g_{k,j}$ we extend the indexing on j to cover these concatenated copies. These p_{k+1} concatenated copies of $\mathcal{G}(p_k)$ correspond to all the numbers from 1 to $\Pi_{k+1} + 1$ which are coprime to Π_k . For the set of generators of Π_{k+1} , we need only remove the multiples of p_{k+1} .

The third step removes the multiples of p_{k+1} . Removing a possible prime amounts to adding together the gaps on either side of this entry. The only multiples of p_{k+1} which remain in the copies of $\mathcal{G}(p_k)$ are those multiples

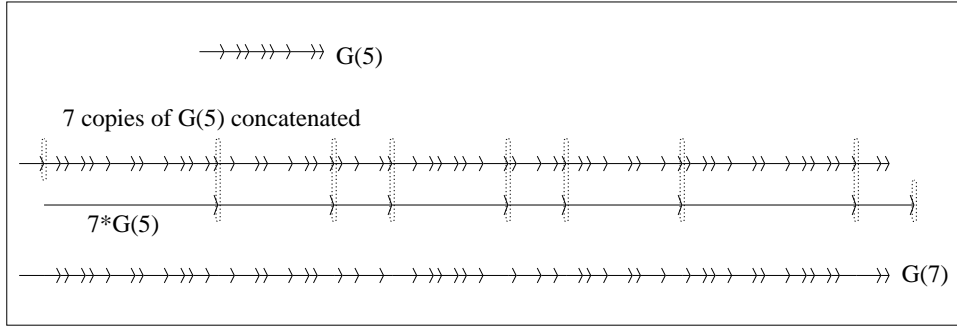

FIGURE 1. An illustration of the recursion that produces the gaps for the next stage of Eratosthenes sieve. The cycle of gaps $\mathcal{G}(7)$ is produced from $\mathcal{G}(5)$ by concatenating 7 copies, then adding the gaps indicated by $7 * \mathcal{G}(5)$.

all of whose prime factors are greater than p_k . After p_{k+1} itself, the next multiple to be removed will be p_{k+1}^2 .

The multiples we seek to remove are given by p_{k+1} times the generators of $\mathbb{Z} \bmod \Pi_k$. The consecutive differences between these will be given by $p_{k+1} * g_{k,j}$, and the sequence $p_{k+1} * \mathcal{G}(p_k)$ suffices to cover the concatenated copies of $\mathcal{G}(p_k)$. We need not consider any fewer nor any more multiples of p_{k+1} to obtain the generators for $\mathcal{G}(p_{k+1})$.

In the statement of R3, the index n moves through the copy of $\mathcal{G}(p_k)$ being multiplied by p_{k+1} , and the indices \tilde{i}_n mark the index j at which the addition of gaps is to occur. The multiples of p_{k+1} in the p_k -sieve are given by p_{k+1} itself and $p_{k+1} * (1 + \Gamma_{k,j})$ for $j = 1, \dots, \Phi_k$. The difference between successive multiples is $p_{k+1} * g_{k,j}$. □

Example: $\mathcal{G}(5)$. We start with $\mathcal{G}(3) = 42$.

- R1. $p_{k+1} = 5$.
- R2. Concatenate five copies of $\mathcal{G}(3)$:

$$4242424242.$$

- R3. Add together the gaps after 4 and thereafter after cumulative differences of $5 * \mathcal{G}(3) = 20, 10$:

$$\begin{aligned}
 \mathcal{G}(5) &= 4 + \overbrace{2424242}^{20} + \overbrace{42}^{10} \\
 &= 64242462.
 \end{aligned}$$

Note that the last addition wraps over the end of the cycle and recloses the gap after the first 4.

Remark 3.2. *The following results are easily established for $\mathcal{G}(p_k)$:*

- i) The first difference between additions is $p_{k+1} * (p_{k+1} - 1)$, which removes p_{k+1}^2 from the list of possible primes.
- ii) The last entry in $\mathcal{G}(p)$ is always 2. This difference goes from -1 to $+1$ in $\mathbb{Z} \bmod \Pi_k$.
- iii) The last difference $p_{k+1} * 2$ between additions, wraps from $-p_{k+1}$ to p_{k+1} in $\mathbb{Z} \bmod \Pi_{k+1}$.
- iv) Except for the final 2, the cycle of differences is symmetric: $g_{k,j} = g_{k,\Phi_k-j}$.
- v) If $g_{k,j} = g_{k,j+1} = \dots = g_{k,j+m} = g$, then $g = 0 \bmod p$ for all primes $p \leq m + 2$.
- vi) The middle of the cycle $\mathcal{G}(p_k)$ is the sequence

$$2^j, 2^{j-1}, \dots, 42424, \dots, 2^{j-1}, 2^j$$

in which j is the smallest number such that $2^{j+1} > p_{k+1}$.

Example: $\mathcal{G}(7)$. Following the steps in Lemma 3.1, we construct $\mathcal{G}(7)$ from $\mathcal{G}(5) = 64242462$. This recursion is illustrated in Figure 1.

R1. Identify the next prime, $p_{k+1} = g_{k,1} + 1 = 7$.

R2. Concatenate seven copies of $\mathcal{G}(5)$:

$$64242462 \ 64242462 \ 64242462 \ 64242462 \ 64242462 \ 64242462 \ 64242462$$

R3. Add together the gaps after the leading 6 and thereafter after differences of $7 * \mathcal{G}(5)$:

$$\begin{aligned} 7 * \mathcal{G}(5) &= 42, 28, 14, 28, 14, 28, 14 \\ \mathcal{G}(7) &= \overbrace{6+424246264242}^{42} + \overbrace{4626424}^{28} + \overbrace{2462}^{14} + \overbrace{6424246}^{28} + \overbrace{2642}^{14} + \overbrace{4246264}^{28} + \overbrace{242462642424}^{42} + 62 \\ &= 10, 242462642466264264684242486462462664246264242, 10, 2 \end{aligned}$$

Note that the final difference of 14 wraps around the end of the cycle, from the addition preceding the final 6 to the addition after the first 6.

Theorem 3.3. *Each possible addition of adjacent gaps in the cycle $\mathcal{G}(p_k)$ occurs exactly once in the recursive construction of $\mathcal{G}(p_{k+1})$.*

Proof. This is an implication of the Chinese Remainder Theorem. Each entry in $\mathcal{G}(p_k)$ corresponds to one of the generators of $\mathbb{Z} \bmod \Pi_k$. The first gap $g_{k,1}$ corresponds to p_{k+1} , and thereafter $g_{k,j}$ corresponds to $1 + \Gamma_{k,j}$. These correspond in turn to unique combinations of nonzero residues modulo the primes $2, 3, \dots, p_k$. In the p_{k+1} copies of $\mathcal{G}(p_k)$, each copy of a particular gap $g_{k,j}$ has its combination of residues augmented by a unique residue modulo p_{k+1} . Exactly one of these has residue $0 \bmod p_{k+1}$, so we perform $g_{k,j} + g_{k,j+1}$ for this copy and only this copy of $g_{k,j}$. \square

Corollary 3.4. *In $\mathcal{G}(p_{k+1})$ there are at least two entries of $2p_k$.*

Proof. In forming $\mathcal{G}(p_k)$, we concatenate p_k copies of $\mathcal{G}(p_{k-1})$. At the transition between copies we have the subsequence $(p_k - 1)2(p_k - 1)$. In $\mathcal{G}(p_k)$ each of the two additions takes place, so the sequences $(p_k - 1)(p_k + 1)$ and $(p_k + 1)(p_k - 1)$ both occur. In $\mathcal{G}(p_{k+1})$ the addition in each of these two sequences occurs in one of the p_{k+1} copies. \square

This corollary provides long runs of composite numbers earlier than the traditional elementary constructions. For example, suppose we were looking for runs of one thousand consecutive composite numbers. In the traditional approach, we would take $p_{169} = 1009$ and note that

$$\{\Pi_{169} + 2, \Pi_{169} + 3, \dots, \Pi_{169} + 1009, \Pi_{169} + 1010\}$$

and

$$\{\Pi_{169} - 1010, \Pi_{169} - 1009, \dots, \Pi_{169} - 3, \Pi_{169} - 2\}$$

are runs of 1009 composite numbers. Using the above corollary, we take $p_{96} = 503$ and note that in $\{p_{97}, \dots, \Pi_{97}\}$ there occur at least two runs of 1006 composite numbers.

4. SPECIFIC CONSTELLATIONS IN $\mathcal{G}(p)$

A *constellation* is a sequence of gaps. In this section, we use the recursion of Lemma 3.1 to count the number of occurrences of a constellation in $\mathcal{G}(p_k)$. Then in the next section we estimate how many of these occurrences survive as constellations among primes smaller than p_{k+1}^2 .

Whether a constellation s continues to occur in $\mathcal{G}(p)$ under the recursion depends on the number of gaps.

Lemma 4.1. *Let s be a constellation of j gaps in $\mathcal{G}(p_k)$. If $j < p_{k+1} - 1$, then copies of s will appear in all $\mathcal{G}(p)$ with $p \geq p_k$.*

Proof. By Lemma 3.1 any constellation is initially replicated p_{k+1} times, in Step R2. But then by Theorem 3.3, each possible addition occurs exactly once, corrupting up to $j + 1$ copies of s . If $j < p_{k+1} - 1$, then at least one copy of s survives intact. \square

By Lemma 4.1, if a constellation is short enough, then it will propagate through the $\mathcal{G}(p)$ until the conditions of the following theorem are met, and from that point on we can enumerate the occurrences of the constellation by the recursive equations provided in the theorem.

Theorem 4.2. *Let s be a constellation of j gaps in $\mathcal{G}(p_k)$, such that the sum of these j gaps is less than $2p_{k+1}$. Let S be the set of all constellations*

\bar{s} which would produce s upon one addition of differences. Then the number $N_s(p)$ of occurrences of s in $\mathcal{G}(p)$ satisfies the recurrence

$$N_s(p_{k+1}) = (p_{k+1} - (j + 1)) * N_s(p_k) + \sum_{\bar{s} \in S} N_{\bar{s}}(p_k)$$

Proof. We account for the number of copies of s which survive the recursion intact, and we add to this the number of new copies of s generated from other sequences.

The j gaps in s can be closed in $j + 1$ ways. Theorem 3.3 tells us that each of these will occur exactly once. If the sum of the gaps in s is less than $2p_{k+1}$, then these closings are guaranteed to occur in distinct copies of s . This establishes the first term on the right-hand side.

Finally, the summation on the right-hand side accounts for occurrences which are generated from other constellations. \square

Corollary 4.3. *Let s be a constellation of j gaps in $\mathcal{G}(p_k)$. If $j < p_{k+1} - 1$, then the number of copies of s , $N_s(p)$, will be dominated by the factors $\prod(p - j - 1)$. Thus all constellations of j gaps grow asymptotically at the same rate.*

Although the asymptotic growth rates of all constellations of j gaps are equal, the initial conditions and driving terms are important. Brent [2] made analogous observations for single gaps ($j = 1$). His Table 2 indicates the importance of the lower-order effects in estimating relative occurrences of certain gaps.

Figure 2 provides a diagram of growths among various constellations. For each constellation s , its growth is dominated by the number j of gaps through the factors $(p - j - 1)$. Those constellations S which produce s after one addition provide the driving terms in the summation, but they are added in without a multiplier, and they themselves grow with factors $(p - j - 2)$, since they are one gap longer than s . Finally, the counts $N_s(p)$ for various constellations will vary by their initial conditions. These initial conditions are the prime p for which s first occurs in $\mathcal{G}(p)$ and the number of these first occurrences.

Neither 2's nor 4's are generated from any other sequence. In $\mathcal{G}(3)$ there is one 2 and one 4, so the numbers of occurrences of these two gaps will continue to be equal through all stages of the sieve.

From Figure 2 or from the symmetry of $\mathcal{G}(p)$, we know that the constellations 24 and 42 will always occur equally often. However, 242 has no driving terms and so it will soon be outnumbered by the constellation 2, 10, 2. The constellation 242 also generates occurrences of the constellations 26 and 62, and these in turn generate 8's; a gap of 6 is generated by the constellations

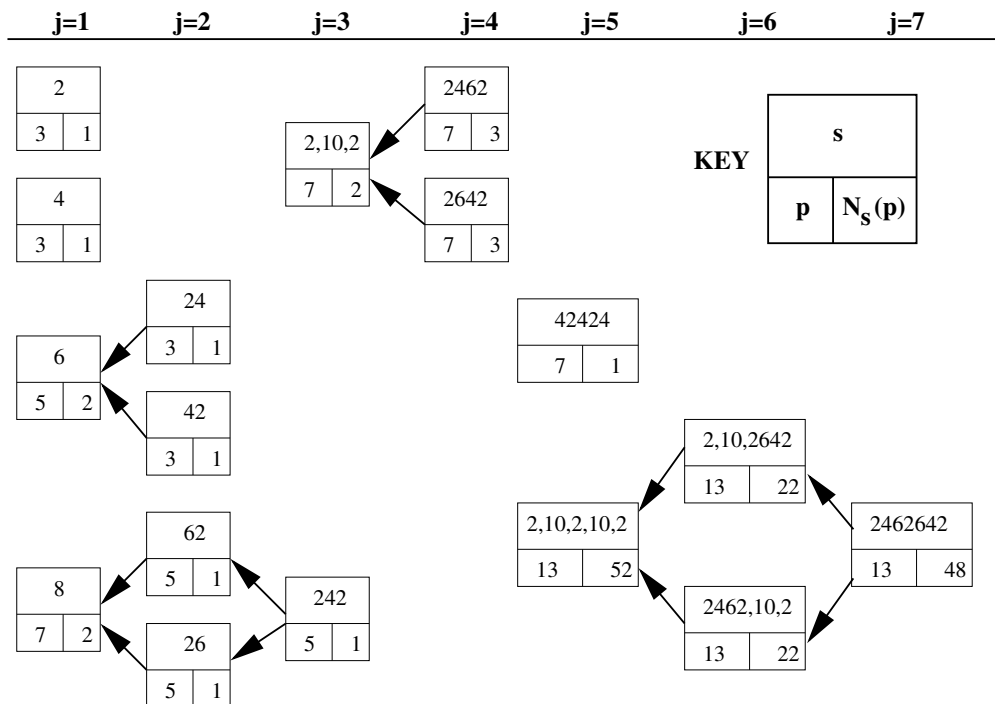

FIGURE 2. The numbers $N_s(p)$ of a constellation s are completely described by figures like this. All constellations of j gaps have identical dominant terms in Theorem 4.2, so we line up our entries for constellations in columns indexed by j . For each constellation s we include its initial conditions: the first prime p for which s occurs in $\mathcal{G}(p)$ and the conditions of the theorem hold; and the number of occurrences of s in $\mathcal{G}(p)$. We indicate driving terms for the recurrence in Theorem 4.2 by directed arrows. Despite any disparities in initial conditions between two constellations of j gaps, the constellation with more driving terms will rapidly become more numerous.

24 and 42, which themselves have no generators. Under the recursion we will eventually have

$$N_2(p) = N_4(p) < N_6(p) < N_8(p).$$

More surprising constellations include 42424 or 2, 10, 2 or even 2, 10, 2, 10, 2. Due to the terms for the sequences 2462 and 2642, the constellation 2, 10, 2 becomes more abundant than the constellation 242. These two equal additional terms in the recursion for 2, 10, 2 fade in their significance compared to the multiplier $(p - 4)$. By $p = 89$, these two terms are

contributing around one-half a percent of the total. Similarly, while the constellations 42424 and 2, 10, 2, 10, 2 both occur, ultimately 2, 10, 2, 10, 2 will be more abundant due to driving terms.

p	$N_2(p)$	$N_{24}(p)$	$N_6(p)$	$N_{242}(p)$	$N_{26}(p)$	$N_8(p)$	$N_{2,10,2}(p)$
5	3	2	2	1	1	0	0
7	15	8	14	3	5	2	2
11	135	64	142	21	43	28	20
13	1485	640	1690	189	451	394	216
17	22275	8960	26630	2457	6503	6812	3096

In the calculation for $N_{2,10,2}(p)$, we can also observe the necessity of the requirement that the sum of the elements in a constellation be less than $2p$. One initial condition for $N_{2,10,2}(p)$ is $N_{2462}(7) = 3$. Since there are four elements in the constellation 2462, we expect the number of these to grow as $(p - 5)$, and without checking, we might assume that there would be 2 such constellations in $\mathcal{G}(7)$. However, the sum of these elements is $14 = 2 * 7$, and in the construction of $\mathcal{G}(7)$ a sum of $2 * 7$ falls perfectly across one copy of 2462. The result is that two of the gaps are closed in this single copy of 2462, letting an additional one of the seven original copies (from step R2) survive. Until p is greater than twice the sum of the elements in the constellation, we cannot be certain that each of the gaps in this constellation will be closed in distinct copies.

From the work above, we have methods for tracking the exact number of copies of any constellation through the stages of Eratosthenes sieve. Unless the constellation occurs in $\mathcal{G}(5)$, it must initially result from the closing of gaps in longer constellations. When a constellation appears in some $\mathcal{G}(p)$, Lemma 4.1 and Theorem 4.2 provide the conditions and formulae for the exact number of this constellation that will appear in each stage of the sieve. This system is illustrated in Figure 2.

5. EXPECTED CONSTELLATIONS OF PRIME NUMBERS

All of the work above is deterministic. We have identified a recursion that produces the cycle $\mathcal{G}(p_k)$ of gaps between consecutive generators of $\mathbb{Z} \bmod \Pi_k$. We are able to identify and count individual gaps and constellations as the recursion progresses. In this section we introduce two conjectures, to help us explore the potential of this approach.

The quantities $N_s(p)$ provide exact counts of the constellation s in the cycles $\mathcal{G}(p)$ as we iterate on p . These counts indicate how often s occurs as a constellation among possible primes. We would like to use this information to draw conclusions about how often s occurs as a constellation among prime numbers.

To estimate how often s occurs as a constellation among prime numbers, we combine two insights. First, all constellations in $\mathcal{G}(p_k)$ from p_{k+1} to p_{k+1}^2 are constellations among primes. Second, the recursion suggests uniform distributions.

Remark 5.1. *In $\mathcal{G}(p_k)$, all the gaps that occur after $g_{k,1} = p_{k+1} - 1$ and before p_{k+1}^2 are actually gaps between prime numbers. For $j > 1$, if $\Gamma_{k,j} < p_{k+1}^2$, then $g_{k,j} = g_{k+j}$.*

Constellations which fall in the interval $[p, p^2]$ are constellations among primes. We want to understand the distribution of the $N_s(p)$ copies of a constellation s over the cycle from 1 to Π_k . Observe that the concatenation step in the recursion produces uniformly distributed copies of every constellation. By using the interval $[p, p^2]$ to sample these approximate uniform distributions of constellations, we can make estimates $E_s(p)$ of how often s occurs as a constellation among primes.

5.1. Nearly Uniform Distributions. The recursion in Lemma 3.1 suggests that if we track the images of some gap g through several stages of Eratosthenes sieve, these images will be almost uniformly distributed in the fundamental cycle. In $\mathcal{G}(p_k)$ pick any gap $g = g_{k,j}$. Step R2 of the recursion creates p_{k+1} copies of this gap, uniformly distributed in the interval $[1, \Pi_{k+1}]$. Step R3 removes two of these copies of g . In $\mathcal{G}(p_{k+2})$, step R2 creates p_{k+2} copies of the set of nearly uniformly distributed $p_{k+1} - 2$ copies of g . These p_{k+2} copies are uniformly distributed in the interval $[1, \Pi_{k+2}]$. After step R3, the $(p_{k+2} - 2)(p_{k+1} - 2)$ images of g in $\mathcal{G}(p_{k+2})$ are approximately uniformly distributed. As we continue applying the recursion, the abundant images of g are pushed toward uniformity by step R2 and trimmed symmetrically by step R3. In Figure 1 we can see this effect after only one stage of the sieve.

The preceding observations apply to constellations as well. For a constellation, the distribution of its images may not well-approximate a uniform distribution until several of the recursions have been applied. If the constellation contains j gaps, then after step R2 in the recursion distributes p copies of s uniformly, step R3 trims $j + 1$ of these copies by closing gaps in the constellation. These $j + 1$ copies of s are trimmed in symmetrical fashion. Although j may initially be almost as large as p , through the recursion p grows while j remains fixed. Before long, the trimming of step R3 will not substantially disrupt the uniformity of the distribution enforced by step R2.

These observations, about the effects of the recursion on the distribution of occurrences of a particular constellation, indicate a uniform distribution, but there is more work to be done in understanding the distribution of copies of s in $\mathcal{G}(p)$. Further investigation will proceed along two lines: computer searches and statistical analyses. For our present purposes we leave the desired result as a conjecture.

Conjecture 5.2. *Under the recursion in Lemma 3.1, all constellations in $\mathcal{G}(p)$ of sum less than $2p$ tend toward a uniform distribution in $\mathcal{G}(P)$ for all primes $P \gg p$.*

Our estimates of the frequency of occurrences of certain constellations require the uniform distribution asserted by this conjecture. However, other results, for example on some conjectures by Erdős and Turán [6], require a much weaker conjecture.

Conjecture 5.3. *Under the recursion in Lemma 3.1, all constellations in $\mathcal{G}(p_k)$ of sum less than $2p_{k+1}$ and with fewer than $p_{k+1} - 1$ gaps occur infinitely often as constellations among larger primes.*

From Lemma 4.1, we know that copies of these constellations will survive throughout the $\mathcal{G}(p)$, and from Theorem 4.2 that the number of copies will grow superexponentially. Our first conjecture postulates a distribution which enables us to count the copies which fall in the intervals $[p, p^2]$ for every p .

This first conjecture suggests that the third step in the recursion has an approximately uniform effect on the uniform distribution of copies created by the second step. The second weaker conjecture asserts only that for some subsequence of the primes, each interval $[p, p^2]$ contains at least one copy of the constellation. Suppose the third step in the recursion removes more copies of a constellation from the ends of the cycle of gaps, so that the superexponential number of copies are clustered in the middle (recall that $\mathcal{G}(p)$ is symmetric). This second conjecture postulates that occasionally a copy of the constellation falls into the interval $[p, p^2]$.

To bolster these conjectures, we can step back and look at the aggregate population of all constellations. Not all constellations can accumulate in the middle of $\mathcal{G}(p)$. Some must fall in $[p, p^2]$. If the distribution for some particular constellation is forever biased strongly toward the middle of the cycle, then the distributions of some other constellations must compensate for this bias. That is, if some constellations fall below the expected number of occurrences, then other constellations must exceed the expectations.

5.2. Estimates. For a given constellation s , we use the approximate uniformity of the $N_s(p_k)$ copies of s in $\mathcal{G}(p_k)$ to estimate the number that survive as constellations among primes. There are Φ_k gaps in $\mathcal{G}(p_k)$. The average length μ of a gap in $\mathcal{G}(p_k)$ is

$$\mu = \frac{\Pi_k}{\Phi_k} \sim e^\gamma \ln p.$$

The limit is due to Mertens, and its derivation is recorded in [11]. In an interval I in $[1, \Pi_k]$, we can expect there to be $|I|/\mu$ gaps. Thus the expected

number of constellations s in an interval I is given by

$$E(s, I) = \frac{N_s(p_k)}{\Phi_k - j + 1} \frac{|I|}{\mu}.$$

The first factor is the fraction of gaps in $\mathcal{G}(p_k)$ that start a copy of s , and the second factor is the expected number of gaps in the interval I . As k gets large, the constant correction of $j - 1$ in the first denominator becomes inconsequential.

Of particular interest to us is the interval $[p_{k+1}, p_{k+1}^2]$:

$$(4) \quad E_s^k = E(s, [p_{k+1}, p_{k+1}^2]) \sim \frac{N_s(p_k)}{\Phi_k} (p_{k+1}^2 - p_{k+1}) \frac{e^{-\gamma}}{\ln p_k}.$$

As a first application of this approach, we estimate the number of twin primes between p and p^2 .

$$\begin{aligned} E_2^k &= (p_{k+1}^2 - p_{k+1}) \frac{1}{\mu} \frac{\prod (p_j - 2)}{\prod (p_j - 1)} \\ &\sim 2e^{-2\gamma} c_2 \frac{p_{k+1}^2 - p_{k+1}}{\ln^2 p_k} \end{aligned}$$

Our estimate for the number of twin primes must be contrasted with those estimates provided by Hardy and Littlewood, which are supported by vast computation [2, 15]:

$$\begin{aligned} \# \{g_i = 2 : p_i \in [p_{k+1}, p_{k+1}^2]\} &\sim 2e^{-2\gamma} c_2 \frac{p_{k+1}^2 - p_{k+1}}{(\ln p_k)^2} \\ \text{vs.} & \\ \# \{g_i = 2 : p_i \in [2, N]\} &\sim 2c_2 \int_2^N \frac{dx}{\ln x} \sim 2c_2 \frac{N}{(\ln N)^2} \end{aligned}$$

Some actual counts C_2^k of the single-gap constellation 2 occurring between p_k and p_k^2 are tabled below. These actual counts are compared to the estimates from the preceding stage of the sieve, E_2^{k-1} , and to the Hardy-Littlewood estimate HL_2^k . The right half of the table compares the counts and estimates for the single-gap constellations 6 and 8.

p_k	C_2^k	E_2^{k-1}	HL_2^k	C_6^k	E_6^{k-1}	C_8^k	E_8^{k-1}
11	8	8	4	7	7	2	1
13	9	9	6	10	10	1	2
101	202	181	152	296	286	104	96
199	574	530	457	898	878	335	312
499	2557	2470	2112	4099	4263	1672	1579
1009	8278	8217	6997	13715	14521	5643	5506
1999	26777	26742	22788	44785	48159	18762	18601
2503	39326	39558	33717	66333	71628	27924	27811
4999	130343	133426	113623	223691	245166	96283	96528
10007	440666	457406	389427	769389	850965	334491	338959
12503	653634	681311	579620	1146148	1271986	499702	508315
14939	895790	936917	797157	1576337	1753990	689398	702709

Twin primes occur in interesting constellations, for example the prime quadruplets constellation $s = 242$. This constellation occurs in $\mathcal{G}(5)$. With $N_{242}(5) = 1$, we calculate the number of expected occurrences of the constellation 242 between p and p^2 . Under the recursion, $N_{242}(p_{k+1}) = (p_{k+1} - 4)N_{242}(p_k)$. So, under our conjecture of uniformity, the expected number of these constellations between p_{k+1} and p_{k+1}^2 is

$$\begin{aligned}
(5) \quad E_{242}^k &= \frac{(p_{k+1}^2 - p_{k+1})}{\mu} \prod_{p_j=5}^{p_k} (p_j - 4) / \Phi_k \\
&= \frac{(p_{k+1}^2 - p_{k+1})}{\mu^4} \prod_{p_j=5}^{p_k} (p_j - 4) \cdot \frac{\Pi_k^3}{\Phi_k^4} \\
&\sim \frac{27}{2} c_4 e^{-4\gamma} \frac{(p_{k+1}^2 - p_{k+1})}{\ln^4 p_k}, \\
\text{with } c_4 &= \prod_{q \geq 5} \frac{q^3(q-4)}{(q-1)^4} = 0.30749 \dots
\end{aligned}$$

This constant c_4 can be derived from the estimates (1) and (3). See for example [22].

The extensive computations of [17] support the Hardy-Littlewood estimates [22] for $s = 242$:

$$\frac{27}{2} c_4 \int_2^N \frac{dx}{\ln^4 x} \sim \frac{27}{2} c_4 \frac{N}{(\ln N)^4}.$$

Calculating $E_{2,10,2}^k$ is more involved because of the driving terms from the constellations 2462 and 2642. We note that for all $p \geq 13$, $N_{2,10,2}(p) > N_{242}(p)$, but that both have the same dominating factor of $p - 4$.

p_k	C_{242}^k	E_{242}^{k-1}	HL_{242}^k	$C_{2,10,2}^k$	$E_{2,10,2}^{k-1}$	$C_{2,10,2,10,2}^k$	$E_{2,10,2,10,2}^{k-1}$
11	2	2	0	0	0	0	0
13	1	1	0	1	1	0	0
101	10	9	5	18	16	1	1
199	20	20	12	35	37	2	2
499	56	67	42	118	135	5	6
1009	167	182	114	325	377	10	13
1999	459	490	308	873	1041	25	29
2503	620	683	431	1249	1464	38	39
4999	1714	1948	1228	3621	4255	84	95
10007	4760	5712	3604	10502	12686	212	243
12503	6657	8118	5114	14872	18113	300	331
14939	8777	10753	6777	19556	24079	378	424

The tables above sample the output from a program that searches for prime constellations, up to the limits of long integer arithmetic and available RAM. The largest prime for which constellations can be counted accurately by this program is 14939. Extending these computational results is one open avenue of research.

Correlations among copies of a constellation are somewhat preserved by the recursion. Our conjecture 5.2 does not take into account these correlations. For example, the constellation 2, 10, 2, 10, 2 occurs in $\mathcal{G}(7)$ and thereafter. This constellation contains two occurrences of 2, 10, 2 and will consequently introduce jumps in $C_k(2, 10, 2)$. Any deviations from a uniform distribution are altered during the recursions. These changes to the distribution are therefore occurring on the scale of Π_k . As a reference point for this scale, the results tabulated in this paper, through $p = 14939$ require only Π_9 , with $p_9 = 23$.

5.3. Refinements. Based on our conjecture about uniformity, we could calculate the expected number of a constellation s that fall between p_{k+1} and p_{k+1}^2 as

$$E_s^k = (p_{k+1}^2 - p_{k+1}) \frac{N_s(p_k)}{\Pi_k}.$$

For small primes we can improve these estimates. The symmetry of $\mathcal{G}(p)$ allows us to refine the denominator to $\Pi_k - 2p_{k+1}$. Observations about the middle of $\mathcal{G}(p)$ allow a further refinement in the denominator. Our estimates do not need to use the entire interval $[1, \Pi_k]$. The cycle $\mathcal{G}(p)$ is symmetric, and its middle constellation is $2^j \dots 42424 \dots 2^j$. Thus we could work over the interval $[p_k, \Pi_k/2 - 2^{j+1}]$ instead; the term 2^{j+1} is the smallest power of 2 greater than p_{k+1} .

These refinements may require us to decrement the numerator slightly, adjusting for occurrences we know we've excluded, e.g. the final 2. We could

adjust the interval $[p, p^2]$ to $[p, p^2 - l]$ to adjust for the sum l of the gaps in the constellation. These refinements are constant or of order p , which become inconsequential rapidly in the face of factors like Π_k .

6. IMPLICATIONS FOR OTHER PROBLEMS ON CONSTELLATIONS

Although Hardy and Littlewood's prime k -tuple conjecture is formulated about differences between primes, we show here that the conjecture has an equivalent formulation as a conjecture on constellations.

To the k -tuple we associate a constellation. Without loss of generality we can assume the k -tuple is in ascending order. From this k -tuple we can derive a sequence of $k - 1$ differences:

$$(6) \quad s_b = (b_2 - b_1), (b_3 - b_2), \dots, (b_k - b_{k-1}).$$

This sequence is the constellation we want to associate with the k -tuple. Notice, however, that the k -tuple conjecture does not require that the primes be consecutive. So while the k -tuple conjecture can be trivially reformulated for a sequence of differences, we have a little work to do to establish that this is equivalent to a conjecture on constellations.

Lemma 6.1. *The k -tuple conjecture is equivalent to the conjecture that the constellation s_b occurs in $\mathcal{G}(p)$ for some p with $2p > b_k - b_1$.*

Proof. For the k -tuple $B = (b_1, \dots, b_k)$ we put the b_i in ascending order, and then associate this with the constellation

$$s_b = (b_2 - b_1), (b_3 - b_2), \dots, (b_k - b_{k-1}).$$

(\Leftarrow) If the constellation s_b occurs in $\mathcal{G}(p)$ with $2p > b_k - b_1$, then this constellation occurs infinitely often as a constellation among primes, and the k -tuple conjecture would be true for B .

(\Rightarrow) Conversely, suppose the k -tuple conjecture were true for B . Then the sequence of differences in (6) occurs infinitely often among the primes. Let p be a prime large enough so that two conditions hold: $2p > b_k - b_1$, and one instance of the k -tuple of primes falls within $\mathcal{G}(p)$. Then in $\mathcal{G}(p)$ there is a constellation

$$G_1 = g_{20} \dots g_{2n_2} g_{30} \dots g_{3n_3} \dots g_{k0} \dots g_{kn_k}$$

such that $\sum_{i=0}^{n_j} g_{ji} = b_j - b_{j-1}$.

As the recursion of 3.1 proceeds, we identify a sequence of constellations G_i which ends with G_N equal to the constellation s_b . In the i^{th} iteration we pick an image of G_i in which one addition $g_{jJ} + g_{j(J+1)}$ occurs. By Theorem 3.3 this addition occurs, and due to the size of p , this is the only addition that occurs in this image of G_i ; so the desired image exists, and we take the resulting constellation as G_{i+1} .

For $N = n_2 + n_3 + \dots + n_k$, G_N is the constellation s_b . □

In [22], Riesel uses Hardy and Littlewood’s work [10] to estimate the numbers of occurrences of the constellations 424 and 242. Nicely [17] has tested the estimate for 242 computationally. The work in Section 5.2 supports the asymptotic order of the estimates. In $\mathcal{G}(5)$ we see the reason for Nicely’s modularity condition $30n + 11$. By applying the recursion a few times, we can sort copies of 242 into branches with more restrictive modularity conditions. For any other constellation s we can observe analogous modularity conditions based on the location of copies of s in $\mathcal{G}(p)$. Finally, $\mathcal{G}(5)$ supports the conjecture [22] that 424 should occur approximately twice as often as 242.

If our weaker conjecture 5.3 is correct, we can provide solutions to some problems posed by Erdős and Turán [6]:

- i) *Spikes*. What are $\limsup g_n/g_{n+1}$ and $\liminf g_n/g_{n+1}$?
- ii) *Oscillation*. Is there an n_0 such that for all $k \geq 1$, $g_{n_0+2k-1} < g_{n_0+2k}$ and $g_{n_0+2k} > g_{n_0+2k+1}$?
- iii) *Superlinearity*. Can $g_j < g_{j+1} < \dots < g_{j+k}$ have infinitely many solutions for every k ?

Spikes. We will construct a sequence $\{s_k\}$ of constellations, such that s_k occurs in $\mathcal{G}(p_k)$, s_k is of the form $g_{k,n_k}2$, and g_{k,n_k} is strictly increasing in k . Consider constellations in $\mathcal{G}(p_k)$ of the form $g2$. For s_k we take a pair with the maximal g . In $\mathcal{G}(7)$, for example, this pair is 10, 2. By Theorem 3.3, in $\mathcal{G}(p_{k+1})$ one of the images of this pair $g2$ has the gap g added to the preceding gap. This shows that the sequence g_{k,n_k} is strictly increasing in k . Thus

$$\limsup g_n/g_{n+1} \geq \limsup (g_{k,n_k}/2) = \infty.$$

By the symmetry of $\mathcal{G}(p)$,

$$\liminf g_n/g_{n+1} \leq \liminf (2/g_{k,n_k}) = 0.$$

Oscillation. An affirmative answer to this question asserts that eventually the gaps between primes oscillate in size. We provide a counterexample. In $\mathcal{G}(7)$, the constellation 24682 occurs. Our conjecture implies that this constellation will occur infinitely often as a constellation among prime numbers. This constellation is incompatible with the proposed oscillation.

Superlinearity. This third problem inquires about sequences of consecutive primes that exhibit superlinear growth. We provide examples of the requested constellations, from which our conjecture implies an affirmative answer to this problem. From Remark 3.2 we recall that in the middle of $\mathcal{G}(p)$ there occurs a constellation of powers of 2: $2^k, \dots, 42424, \dots, 2^k$. We can make this constellation arbitrarily long by taking p large enough. The

right half of this constellation is an increasing sequence of k gaps. Assuming our conjecture holds, this constellation will occur infinitely often as a constellation among primes.

Our work above also provides insight into the search for dense clusters of primes [22]. One line of research looks for constellations among the small primes to show up again later, among larger primes. Theorem 3.3 and Lemma 4.1 indicate limits on these searches.

7. CONCLUSION

We have studied directly the cycle of gaps produced by each stage of Eratosthenes Sieve. The work above can be divided into two parts: a deterministic recursion for $\mathcal{G}(p)$, followed by statistical estimates under an assumption of approximately uniform distributions.

Based on the recursion for the p -sieves, we have conjectured that all constellations, which occur in $\mathcal{G}(p)$ for some prime p and the sum of whose gaps is less than $2p$, tend toward a uniform distribution in later stages of the sieve. From this conjecture, we can make estimates of the number of occurrences of a constellation between p and p^2 for the new prime p at each stage of the sieve; all constellations which occur before p^2 actually occur as constellations between primes.

We posed two conjectures, either of which imply that every sufficiently small constellation in $\mathcal{G}(p)$ occurs infinitely often as a constellation among prime numbers.

Our stronger conjecture asserts that under the recursion of Eratosthenes sieve, the images of a constellation are distributed approximately uniformly in the fundamental cycle. This conjecture allows us to estimate how many copies of a constellation s occur in the interval $[p, p^2]$, which estimates compare favorably to the results from our initial computer searches. For single gaps or for constellations consisting only of 2's and 4's, other estimates are available [10, 2, 22, 17], and these estimates agree at first order to ours.

This conjecture 5.2 on uniformity provides many open problems. In our estimates, we use the interval $[1, \Pi_k]$ as the sample space for the conjectured uniform distribution. Simple observations about the structure of $\mathcal{G}(p)$ allow us to adjust the sample space. These refinements are on the order of p and so improve our estimates only for very small prime numbers. Are there any refinements that will improve our estimates in the large?

While the statistics in these estimates may be refined, with the weaker Conjecture 5.3 we have addressed three problems posed by Erdős and Turán [6].

REFERENCES

1. R.P. Brent, *The first occurrence of large gaps between successive prime numbers*, Math. Comp. **27** (1973), 959–963.
2. ———, *The distribution of small gaps between successive prime numbers*, Math. Comp. **28** (1974), 315–324.
3. ———, *Irregularities in the distribution of primes and twin primes*, Math. Comp. **29** (1975), 42–56.
4. P.A. Clement, *Congruences for sets of primes*, AMM **56** (1949), 23–25.
5. H. Cramér, *On the order of magnitude of the difference between consecutive prime numbers*, Acta Math. **2** (1937), 23–46.
6. P. Erdős and P. Turán, *On some new questions on the distribution of prime numbers*, BAMS **54** (1948), 371–378.
7. A. Granville, *Unexpected irregularities in the distribution of prime numbers*, Proc. ICM'94 Zurich, vol. 1, Birkhauser, 1995, pp. 388–399.
8. G. Greaves, *Sieves in number theory*, Springer, 2001.
9. B. Green and T. Tao, *The primes contain arbitrarily long arithmetic progressions*, submitted manuscript, 2003.
10. G.H. Hardy and J.E. Littlewood, *Some problems in 'partitio numerorum' iii: On the expression of a number as a sum of primes*, G.H. Hardy Collected Papers, vol. 1, Clarendon Press, 1966, pp. 561–630.
11. G.H. Hardy and E.M. Wright, *An introduction to the theory of numbers*, Clarendon Press, 1938.
12. K.H. Indlekofer and A. Jani, *Largest known twin primes and Sophie Germain primes*, Math. Comp. **68** (1999), no. 227, 1317–1324.
13. M.F. Jones, M. Lal, and W.J. Blurdon, *Statistics on certain large primes*, Math. Comp. **21** (1963), 103–107.
14. H.L. Montgomery and R.C. Vaughan, *On the distribution of reduced residues*, Annals of Math., 2nd series **123** (1986), no. 2, 311–333.
15. T.R. Nicely, *Enumeration to 10^{14} of the twin primes and Brun's constant*, Virginia J. Science **46** (1995), no. 3, 195–204.
16. ———, *New maximal prime gaps and first occurrences*, Math. Comp. **68** (1999), no. 227, 1311–1316.
17. ———, *Enumeration to $1.6 * 10^{15}$ of the prime quadruplets*, in preparation, 2003.
18. B.K. Parady, J.F. Smith, and S.E. Zarantonello, *Largest known twin primes*, Math. Comp. **55** (1990), 381–382.
19. C. Pomerance, *The prime number graph*, Math. Comp. **33** (1979), no. 145, 399–408.
20. P. Ribenboim, *The new book of prime number records*, Springer, 1996.
21. I. Richards, *On the incompatibility of two conjectures concerning primes*, Bull. AMS **80** (1974), 419–438.
22. H. Riesel, *Prime numbers and computer methods for factorization*, 2 ed., Birkhauser, 1994.
23. J. Young and A. Potler, *First occurrence of prime gaps*, Math. Comp. **52** (1989), 221–224.